

# Service Bulletin

## Fuel Systems

Bulletin No.: RS-74  
                   Rev. 1  
 Date: 11/15/80  
 Revised: 8/15/86

**Subject:** NOZZLE ASSEMBLY, AIR BLEED, P/L 2524041-2 TO -3 MODIFICATION OF.

1. PLANNING INFORMATION:

A. Effectivity:

All Nozzle Assemblies covered by Parts List Number 2524041-2.

B. Reason:

To provide detailed instructions for the modification of the Air Bleed Nozzle Assembly listed above to incorporate the new seat and ball valve assembly.

C. DESCRIPTION:

Replace the existing seat and valve assembly with the new seat and ball valve assembly.

D. COMPLIANCE:

Operating Activities: Information only.

Overhaul Activities: Comply at overhaul.

E. APPROVAL: None.

F. MANPOWER:

Approximately 0.5 additional man-hours required at overhaul.

G. MATERIAL AVAILABILITY:

<u>Part No.</u>	<u>Qty.</u>	<u>Nomenclature</u>	<u>Availability</u>
364868	1	Nut	Bendix Distributors
364447	1	Washer	Bendix Distributors
383442	2	Cup	Bendix Distributors
2540887	1	Diaphragm	Bendix Distributors
2525223	1	Valve	Bendix Distributors
2539346	1	Seat	Bendix Distributors
2541937	1	Spring	Bendix Distributors

1. PLANNING INFORMATION: (Continued)

H. TOOLING:

Locally manufactured.

I. WEIGHT AND BALANCE:

Not affected.

J. REFERENCES:

None.

K. PUBLICATIONS AFFECTED:

Overhaul Manual and Illustrated Parts List, Model RS-10FB1. Bendix Form 15-368B.

2. ACCOMPLISHMENT INSTRUCTIONS:

A. During the course of overhaul of the Parts List No. 2524041-2 Air Bleed Nozzle Assembly used with the RS-10FB1 Fuel Injector, proceed as follows: (Refer to figure 4-4 of the affected publication).

(1) Locally fabricate a puller and remove the P/N 367679 seat from body assembly (23).

(2) Apply Loctite Hydraulic Sealant sparingly to the OD of the new P/N 2539346 seat.

NOTE: Loctite products are procurable from Loctite Corporation, 705 North Mountain Road, Newington, Connecticut 06111.

(3) Press the new Part Number 2539346 seat into body with an arbor press to the dimension indicated in Figure 1 of this directive. Wipe excess sealant from the bushing and body with MEK or acetone.

(4) Assemble together parts (1 through 6, Figure 2) of this directive and tighten nut (1) to a torque value of 5-7 inch-pounds. Retorque to original value after 20 minutes. Retorque only.

(5) Reassemble the Air Bleed Nozzle Assembly as outlined in the affected publication except discard the spring (25) and valve assembly (24) and install the parts assembled in the preceding step (4) in place of diaphragm assembly (13). Install spring P/N 2541937 in place of P/N 367649.

(6) Functionally test the Air Bleed Nozzle Assembly as outlined in the affected publication.

2. ACCOMPLISHMENT INSTRUCTIONS: (Continued)

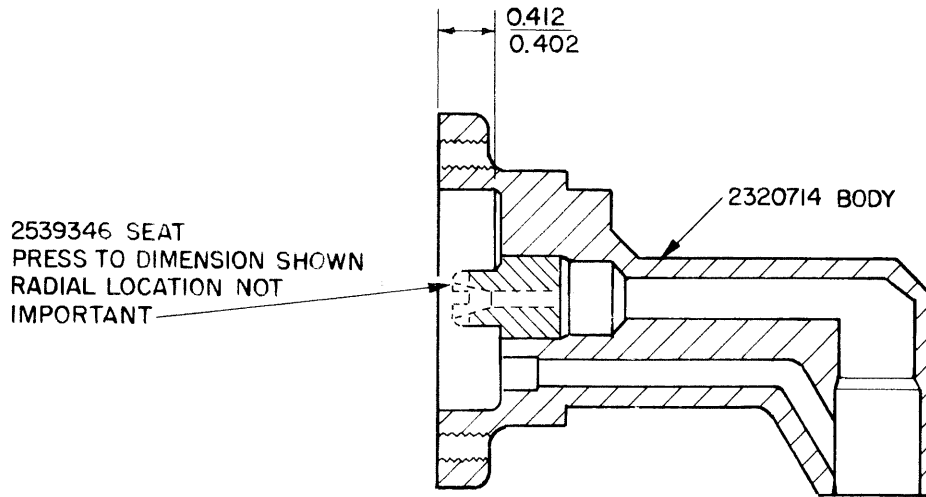

Figure 1.

LA-6361

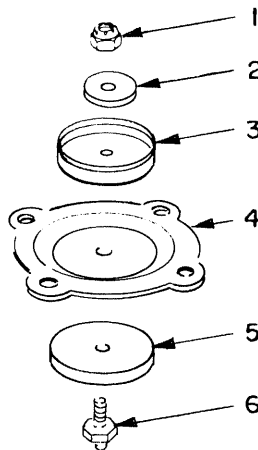

Figure 2.

LA-6362

2. ACCOMPLISHMENT INSTRUCTIONS: (Continued)

B. IDENTIFICATION:

Since this Air Bleed Nozzle Assembly does not incorporate an identification plate, it is permissible to etch the parts list and new issue number on the cover.

Old P/L and Issue No.

2524041-2

New P/L and Issue No.

2524041-3

3. MATERIAL INFORMATION:

<u>New P/N</u>	<u>Qty.</u>	<u>Nomenclature</u>	<u>Old P/N</u>	<u>Disposition</u>
364868	1	Nut		
364447	1	Washer		
383442	2	Cup		
2540887	1	Diaphragm	2520708 (Assy)	Scrap
2525223	1	Valve		
2539346	1	Seat	367679	Scrap
		Valve Assembly	2521329	Scrap
		Spring	367684	Scrap
2539348	1	Body	2520707	Rework
2541937	1	Spring	367649	If serviceable use elsewhere



K. R. Dettweiler  
Manager, Product Support