

Service Information Letter - Fuel Systems

SMALL RECIPROCATING
ENGINES

ALL RSA

No. 17, Rev. 1

Issued 2-5-82

Page 1 of 1

SUBJECT: TOOLING CHANGE FOR ALL RSA FUEL INJECTORS.

PURPOSE: To introduce a new type Loctite Applicator, Part Number 2550982.

REASON FOR REVISION: To add CAUTION.

CAUTION: USE ONLY APPLICATOR PART NUMBER 2550982 AND APPLY LOCTITE VERY SPARINGLY. EXCESSIVE LOCTITE IS LIKELY TO TRAVEL DOWN THE STEM AND LOCK-UP THE REGULATOR AIR SIDE.

The new Loctite applicator is introduced to reduce the amount of Loctite applied to the regulator nut, part number 2539449.

To apply Loctite, dip the pointer of applicator, part number 2550982 into Loctite and carefully deposit a small amount of Loctite to the center of the regulator nut and assemble on stem.

After final calibration, apply a small amount of Loctite to the threads above the nut.

Loctite applicators, part numbers 2550998 and 2550999 are not to be used.

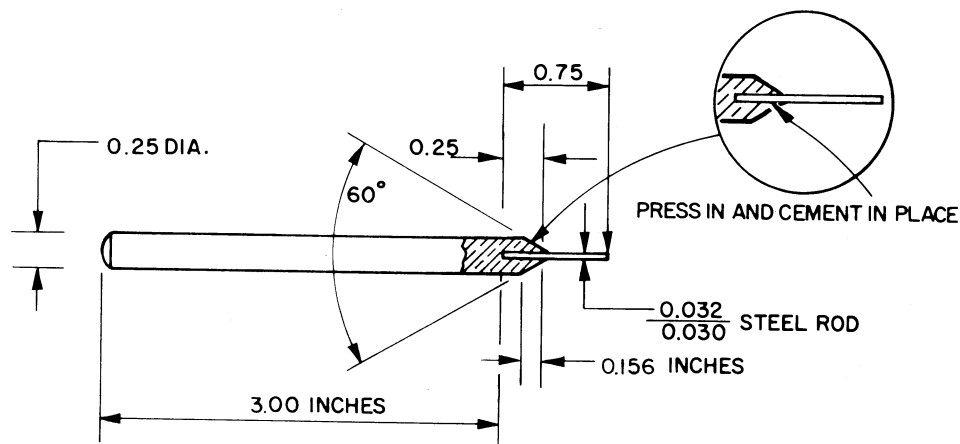

Loctite Applicator P/N 2550982

K. R. Dettweiler
K. R. Dettweiler
Manager of Service



**Energy Controls
Division**

717 N. Bendix Dr., South Bend, Indiana 46620